

REVISION	DATE	CHANGE DESCRIPTION	PROVIDE BY
01	2019-03-27	Standards were changed, dimensions were added.	Bieganowski
02	2019-11-09	Drawing number has been changed, number of elements has been changed, remarks has been updated.	Bieganowski

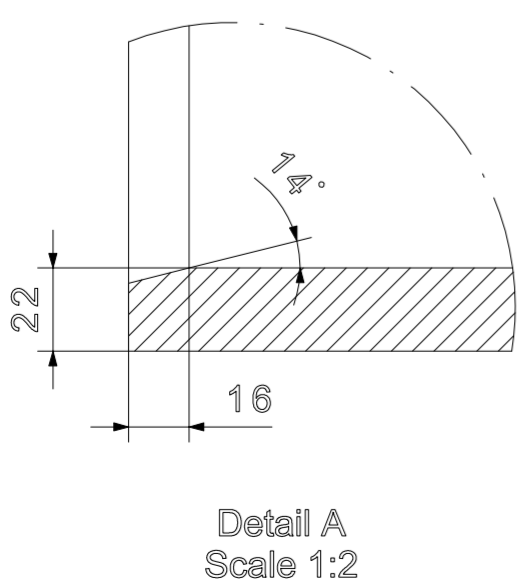
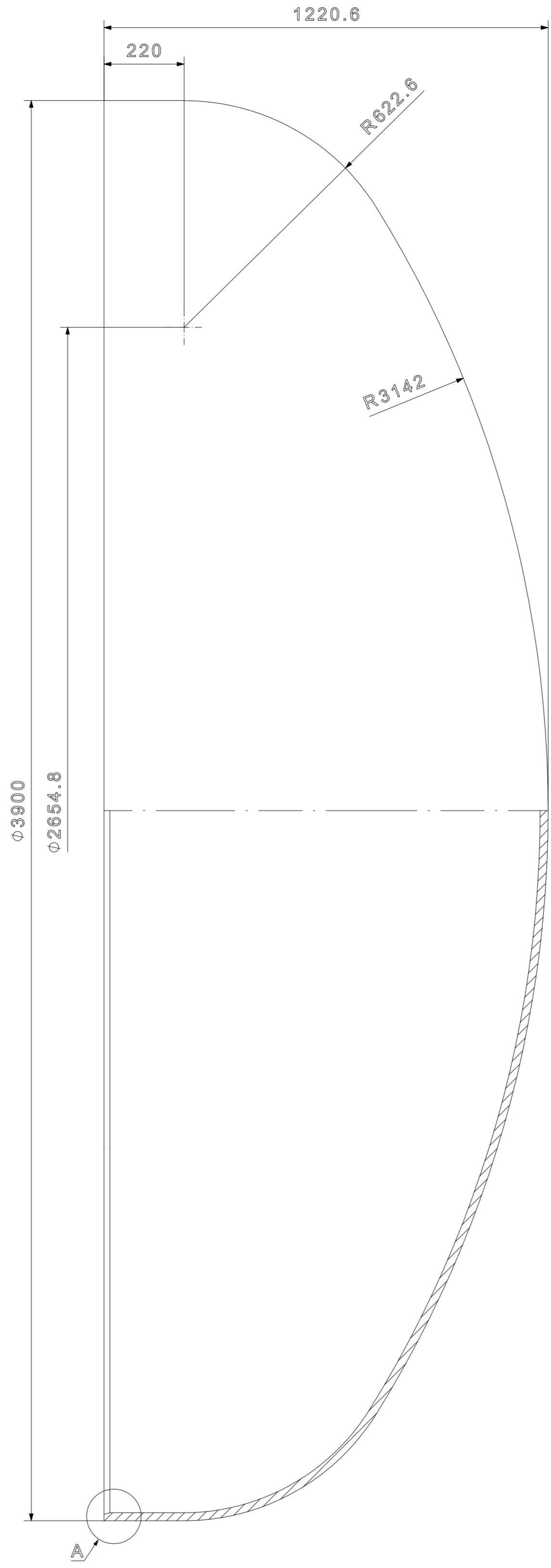

- REMARKS:
1. Dimensions without tolerance in according to ISO 13920-BF, ISO 2768-mK.
 2. Part make in according to DIN 28013.
 3. Minimum thickness of a dish end should not be less than 22 mm.

Drawings are property of REMONTOWA LNG SYSTEMS SP. z o.o. and can not be copied photographed or made available to third parties without permission.		REMONTOWA LNG SYSTEMS			
DREW		DRAWING TITLE			
mgr inż. M. Bieganowski		Dish end (without hole)			
CHECKED	DATE	SIZE	DRAWING NUMBER	MATERIAL	REVISION
dr inż. J. Polński	2018-11-15	A2	RLS.01.032.01	1.4435	02
DESIGNED	DATE	SCALE	WEIGHT (kg)	QUANTITY	SHEET
dr hab. inż. J. Skrzypacz		1:10	3 300,19	1	1/1